

TRIP TO ENGLAND 7. - 18. AUGUST 2014



The following day, Tuesday the 12th, we wake up to glorious sunshine and calm weather.



Ready to continue.



Much scenery around here.



Then more work with the locks.



I and Anni also should be on a picture together.



Continuing working the locks again.
Now both Anni and Eldor are quite skilled.
They assist the the crew on the boat going up before we are going down.



I have moored the boat and are standing here, looking at the lock passage.

The other boat crew is taking over.



Then it is our turn. Here I take the boat into the lock chamber.

Almost in.



Here Anni and Eldor is opening the lock paddles on either side to let the water out of the lock chamber.



The water is out and they can open the lock gates on either side.



More scenery.



Right after this, on Tuesday the 12th of August, we moored. This was an extra long day, but now we had caught up with the delay from the first day. Everyone was tired and we went early to bed.

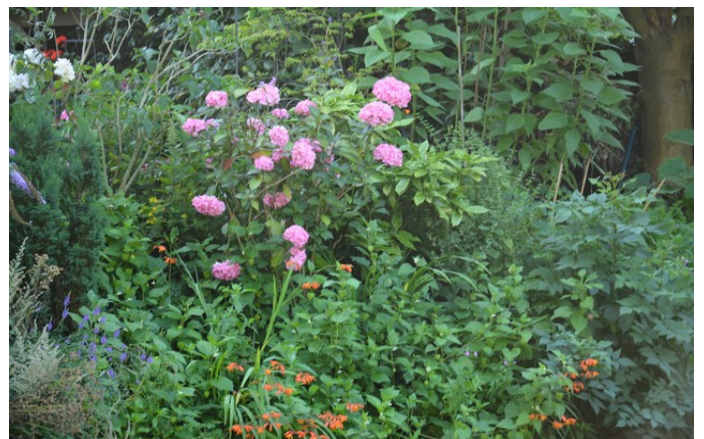

New nice day, Wednesday, August the 13th. It is blue sky and light clouds.



We are driving through nice dwelling areas.



The cat is out, keeping watch.

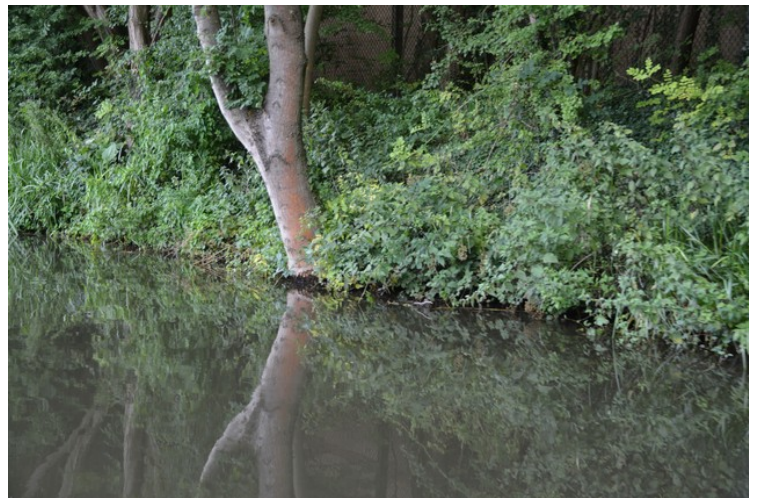



Here we take the evening at Rode Heath. This day was not that long, for now we are on schedule.



New day, Thursday the 14th of August.
Nice houses here.



Here we come to Harecastle tunnel. It is over 2.6 km long
and normal time to run through is 45 minutes.



We have a boat behind us and it lights up the ceiling of the tunnel, so when we look from bow to back, it looks like this.



Approaching the exit.



When we look back it looks still like this.



Almost out.



Here we are out.



Looking behind, it looks like this.



I give full rudder and full throttle to manage the turn after we come out.



Good bye Harecastle tunnel.



There are many boat here, waiting to be let through the other way.



We have to take to the left of the bridge pillar.



The water is pretty brown here by the tunnel.



It looks nicer a little further away.



More people sitting fishing.



We stopped for the night as planned in Rode Heath. Now we had an iron grip on this round, and we celebrated that we were early on the scheduled stop and that we had come through Harcastle Tunnel, about which Anne Berit was a little anxious.



Here I and Eldor have a “drivers beer” after good work.



We planned to eat at Broughton Arms. I am ready.



Everybody are ready.



Here we have arrived to the pub and we order food and drinks.



We find a table with a good bench to sit on.



The bar has an impressive selection of beers in the taps.



We had «Fish and Chips», and it was very good.
The wine was good as well.



«Cheers»



We must have a cigar for the great food.
Here we sit at tables outside the pub.



Nice lamp outside.



Here we see the pub from outside.



We went over to the fence, where we could see over to the boat.



There was Athletics Championships. So many sat and watched it on TV.





Here we are satisfied and tired, so it's time to go.



The neighboring houses to the pub.



The next day, Friday, August the 15th, Anne Berit feeds the ducks that meet the boat and waiting for food.

This day we were up at 5 o'clock, because I woke up and began to think that my wallet had been falling out of the jacket many times when we were in the pub the night before. I had to get up and check if the wallet came back to the boat. I could not find it anywhere, and we were getting ready to go to the pub to check if it could be along the road where we had walked. Fortunately, Anne Berit double checked everything before we went. It had fallen out of my jacket there on the couch, and there was a jacket over.

Great was the relief then.



The ducks are fighting over the food.



Locking ahead.



A lock with shut gates.



The boat is in the lock chamber ready to go down.



The lock navvies at work.



Horses are grazing near the lock.



Out of the lock.



New lock soon ready to open.



The gates are open and it is ready to go out.



The canal further on.



This is a double lock.

More horses.

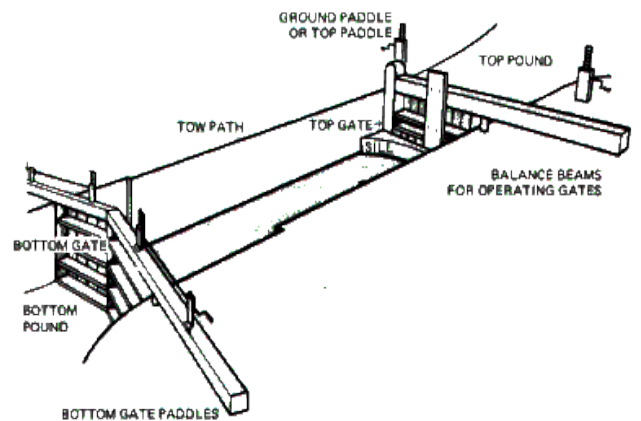



Eldor having a good time on the bow.



Anne Berit is ready to take pictures.



Anni too is ready to take pictures.



Out of a new lock.



This is a boat that is used when the channels are to be maintained.



On the way to work with a new lock.



We are approaching Middlewich again.



We can now see the last lock, which we are going to get through the next day. We stopped here before the lock to have the last night on the boat. When we have done this round, we have driven 175 km and operated and run through 94 locks. Normal average time on this round is 55 hours, ie. almost 8 hours per day over 7 days. We did not note our time consumption, but it was probably about average.



This pub is located right beside the lock, and we went there to eat. Standing outside the entrance.

The Kings Lock has new owners from June 2014. According to reviews on the Internet, the food here has become very good. We thought it was good too.

When we ordered food, we were invited to sample 3 different local whiskey types.



Eldor, who is a whiskey expert, considers two of these against each other.



A cheerful bunch.

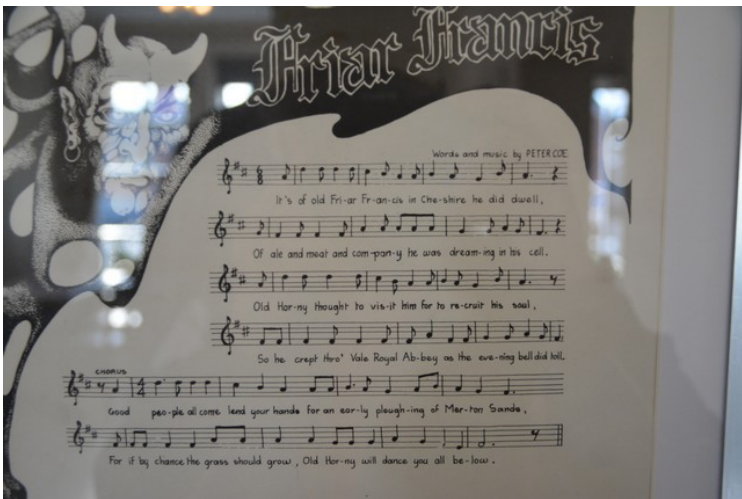

There are lots of pictures (folk music and notes) on the walls





A model of a canal boat used for maintenance work.



Anne Berit had Sailors Plank. It does not look good, but she said it was extremely good.



After the good food I had to have a cigar.



A pear tree with incredibly many pears.

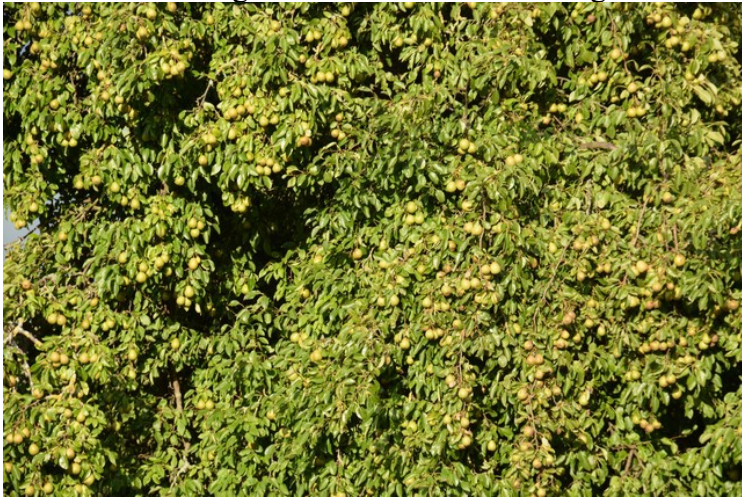

We can see it better here.



The sign outside.

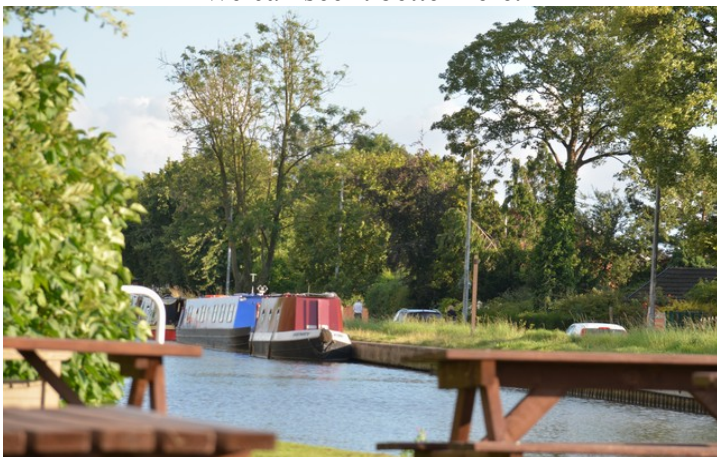

Here we can see our blue boat on the other side of the canal.



More people are sitting outside.



These ladies noticed that we took pictures, and they asked if we wanted them to take pictures of all of us.



Here we are.



This boat went up the lock while we were sitting there.



Evening on the canal.



The next day, Saturday the 15th, is the day when we have to deliver the boat back. It must be submitted before nine o'clock in the morning, so right after breakfast, it is to loosen the moorings and go down through the locks. I cast off at the rear.



Eldor is casting off at the bow.



The last thing that has happened in the lock, is that a boat has gone up. Then the lock chamber is full of water, and it is ready for the boat to go right in.



Anni is opening the upper lock gate.



Here we see from the top of the locks up to the bridge where I and Anne Berit was the first day. That day we traveled by boat into the channel that can be seen to the left.



Anni is waiting for the boat to come into the lock chamber. Today is an examination day for Eldor. He is going to take the boat all by himself through the locks, and to the delivery site.



I'm working one of the lock gates.



Eldor in the lock chamber.



Here we are approaching the delivery site.
Eldor received a passing grade.



Inside the store of Middlewich Narrowboats.
We asked the reception to call for a big taxi that could
take us to Manchester.



Here we are waiting for the taxi to arrive. The staff serves
us coffee while we wait.



Here we are in Manchester having a small lunch at Bar &
Grille.



Outside the bar.



We had made a reservation at [Le Ville Hotel](#) in the down
town of Manchester. It is located right next to a canal that
runs through Manchester, [Ashton Canal](#).

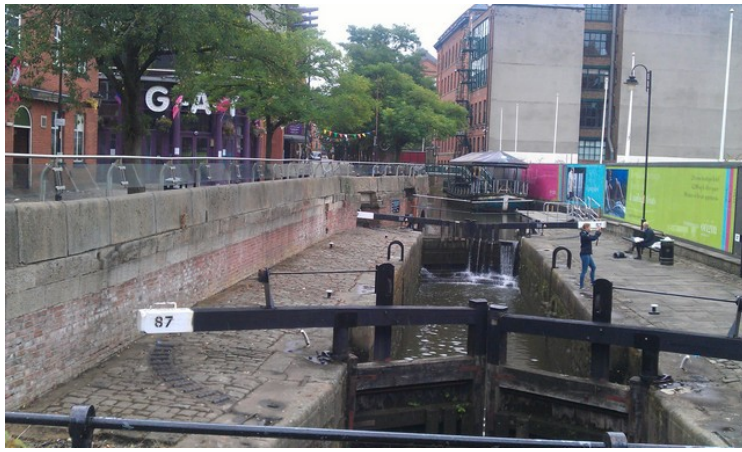

Just beyond the hotel is a lock.



The canal runs between high houses in downtown Manchester.



The next day we visited the brother of Anne Berit who moved from USA to Manchester in 1913. Here are his daughters, Leela, Madelaine and Evelyn. The dog wants to sit on the lap.



The dog is friends with me as long as I bothered to scratch it.

It will be scratched constantly.



Then it is time for food. Deborah and Asbjørn is making the buffet table.



Here it is ready.



Mother of Debbi (Deborah) and myself.



Afterwards of course cakes and coffee.

When we booked the hotel, we did not know that it is situated in an area called [«The gay village»](#).

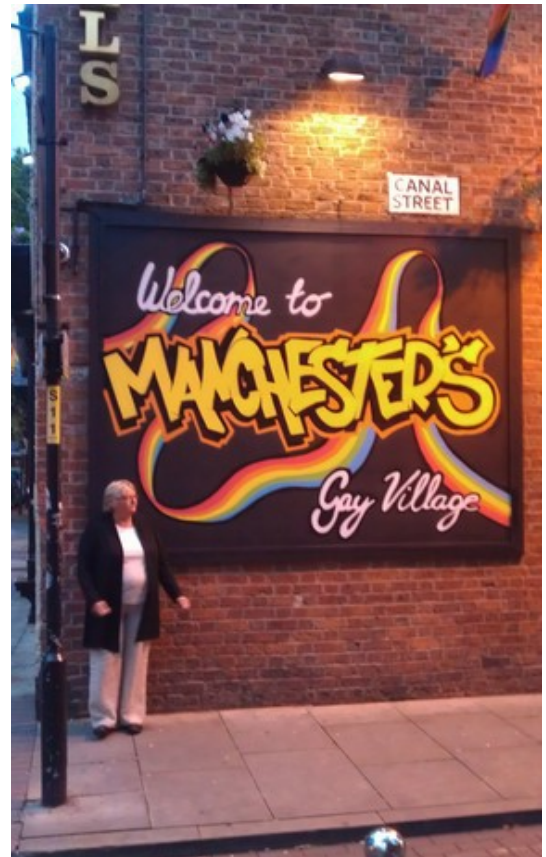



Here we are outside the hotel.

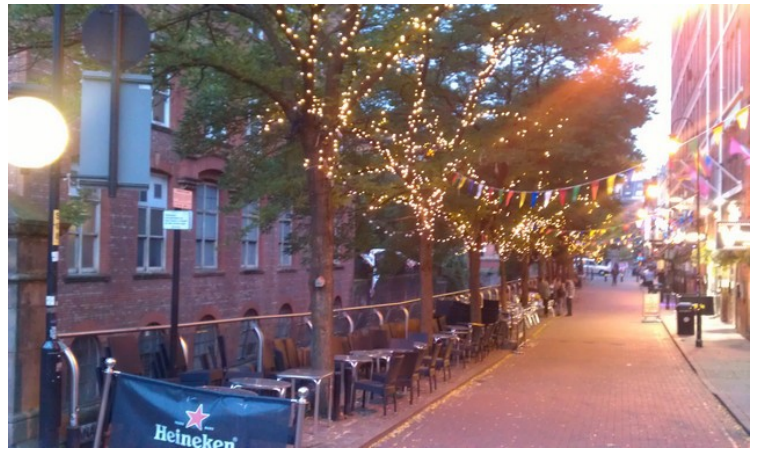

The trees along the canal is garnished with light bulbs.

On Monday we took a taxi to the airport. This trip went directly from Manchester to Oslo - Gardermoen, so our bags were not lost this time. From the airport, we took the airport bus to Kongsvinger, and a taxi from the station and home.